



PROFESSIONAL
THINKING

PRODUCT SHEET EKL 823

TECNOEKA SRL - VIA MARCO POLO, 11 - 35010 BORGORICCO - PADOVA - ITALY - TEL. +39 049 5791479 +39 049 9300344 - FAX +39 049 5794387 - E-MAIL: INFO@TECNOEKA.COM - WWW.TECNOEKA.COM - WWW.TECNOEKA.RU

EKL 823 – PROOFER 8 TRAYS/GRIDS (435x345 mm)

EKA EVOLUTION LINE

PROOFERS



Sturdy and compact, this appliance is a trusted ally for pastry chefs or bakers wanting to drastically reduce proving times compared to traditional processes, but without compromising the quality of the results.

It features a modular design so that it goes with the electric convection ovens from the 4-pan snack series.

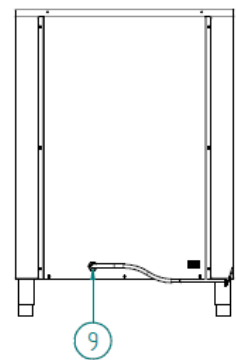
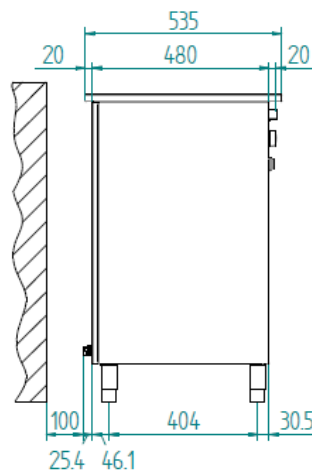
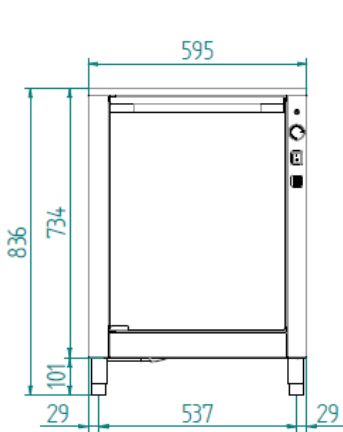

LEGEND

1	USB PORT	11	DON'T CLOG UP VENTILATION OPENINGS
2	SERIAL PORT	12	WATER INLET MAX. 200 kPa
3	PLUG FOR CORE PROBE	13	SOFTENED WATER INLET MAX 200 kPa
4	WATER OUTLET TUBE	14	BOILER CLEANING INLET
5	WASHING WATER INLET	15	DON'T OPEN CAP WHILE WORKING
6	SOFTENED WATER INLET	16	GAS INLET THREADED JOINT 3/4"
7	WATER INLET	17	POWER SUPPLY TO TOP OVEN
8	STEAM OUTLET	18	PRE-CARVED HOLE FOR BOTTOM OVEN POWER SUPPLY
9	ELECTRIC CABLE FIXER	19	STEAM SUCTION PIPE
10	CAUTION! HOT SURFACE		





**PROFESSIONAL
THINKING**

PRODUCT SHEET EKL 823

TECNOEKA SRL - VIA MARCO POLO, 11 - 35010 BORGORICCO - PADOVA - ITALY - TEL. +39 049 5791479 +39 049 9300344 - FAX +39 049 5794387 - E-MAIL: INFO@TECNOEKA.COM - WWW.TECNOEKA.COM - WWW.TECNOEKA.RU

DIMENSIONAL FEATURES			FUNCTIONAL FEATURES		
DIMENSIONS	W	D	H	POWER	ELECTRICITY
PROOFER DIMENSIONS (mm)	595	545	840	CAPACITY	N° 8 TRAYS (429x345 mm)
CARDBOARD BOX DIMENSIONS (mm)	630	564	828*	TYPE OF COOKING	/
PROOFER DIMENSIONS (inches)	23,42	21,45	33,07	HUMIDIFICATION	/
CARDBOARD BOX DIMENSIONS (inches)	24,80	22,24	32,59	PROOFING CHAMBER	AISI 430 STAINLESS STEEL
PROOFER WEIGHT (kg)	25,8			WATER OUTLET	/
PACKED PROOFER WEIGHT (kg)	28,6			STEAM OUTLET	/
PROOFER WEIGHT (lbs)	56,87			TEMPERATURE	30 ÷ 60°C
PACKED PROOFER WEIGHT (lbs)	63,05			TEMPERATURE CONTROL	THERMOSTAT
DISTANCE BETWEEN RACK RAILS (mm)	74			CONTROL PANEL	ELECTROMECHANICAL – RIGHT SIDE
ELECTRICAL FEATURES			N° OF PROGRAMS		/
POWER SUPPLY (kW)	1,2			PROGRAMMABLE COOKING STEPS	/
FREQUENCY (Hz)	50/60			PRESET TEMPERATURE	/
VOLTAGE (Volt)	AC 220/230			PRE-HEATING FUNCTION	/
N° OF MOTORS	/			DOOR	LEFT SIDE HINGED DOOR
RPM	/				
N° OF RESISTORS	1 X 1,2 kW			EQUIPMENT	
LIMIT CONTROL	/			LATERAL SUPPORTS	1RIGHT + 1LEFT
PROTECTION AGAINST WATER	/			CABLE	SINGLE-PHASE [3G 1,5] - L=1600 mm
LIGHTING	/				
PLUS			MODULARITY		
NEW DOOR				OVENS	EKF 423 SERIES
			ACCESSORIES		
				OPTIONAL PACKAGE	COD. 01300280 PALLET (800x1200x118mm)
				WHEELS KIT	COD. KKR822

*Packed without feet (feet in a separate bag)

