

Model: GENIUS^{MT} 6-11 Gas (boilerless)



Dimension:

Width: 36 3/8 inch / 925 mm
 Depth: 31 3/4 inch / 805 mm
 Height: 33 1/8 inch / 840 mm
 Weight: 291 lbs / 132 kg

Number of sheet pans: 6 x full size 18" x 26"
Number of Hotel pans: 6 x full Steam Pan
 12" x 20" x 2"

Distance between rails: 2 5/8 inch / 67 mm

Connected elec. Load: 1 kW
 Connected gas load: 41000 Btu/Hr

Electrical:

Voltage: 110 - 130 VAC
 Phases: 1 phase
 Hz: 50 or 60
 Factory recommended
 Amperage: 9 amp
 Maximum fuse rating: 15 amp

GAS UNITS:

**SUPPLIED WITH A AWG CORD AND PLUG.
 DEDICATED 2 POLE CIRCUIT BREAKER
 REQUIRED. DO NOT CONNECT TO GFCI, USE
 GFEP OR HARDWIRE APPLIES TO ALL GAS UNITS.**

Certification: ETL, ETL Sanitation
Protection (water tight): IPX 5

Heat emission:

- latent 4095 Btu/Hr
 - sensitive 3480 Btu/Hr

Noise level: < 70 dB (A)

Cold water inlet: two (2) 3/4 inch garden hose connection
Drain: 2 inch / 50 mm

IT IS THE SOLE RESPONSIBILITY OF THE OWNER/ OPERATOR/PURCHASER OF THIS EQUIPMENT TO VERIFY THAT THE INCOMING WATER SUPPLY MEETS AND COMPLIES WITH THE WATER QUALITY SPECIFIED. NON-COMPLIANCE WITH THESE MINIMUM STANDARDS WILL POTENTIALLY DAMAGE THIS EQUIPMENT AND/OR COMPONENTS AND VOID THE ORIGINAL EQUIPMENT MANUFACTURER'S WARRANTY.

Soft water quality:

- total hardness ≤ 3° dH / 3 grains/gal
 - pH value 7,0 - 8,5
 - conductivity max. 90 µS/cm³
 - Cl: max. 240 mg/gal
 - SO₄: max. 400 mg/gal
 - SiO₄: max. 40 mg/gal
 - Fe: max. 0,2 mg/gal
 - Mn: max. 0,2 gal/l
 - Cu: max. 0,2 mg/gal
 - Cl₂: max. 0,40 mg/gal

Water pressure: 60 PSI (min. 35 - max. 87 PSI)

Water flow rate:

- Soft water 4,00 gal/h (at 60 PSI)
 - Hard water 14,50 gal/h (at 60 PSI)

1. Drain
2. Feet, adjustable +/- 0,4 inch (10 mm)
3. Cleaner connection
4. Rinsing agent connection
5. Soft water connection
6. Hard water connection
7. Potential equalization
8. Electrical cable connection
9. Air filter
10. Energy optimization connection (for electrical devices only)
11. Potential-free contact (optional) (for electrical devices only)
12. Gas line connection (for gas devices only)

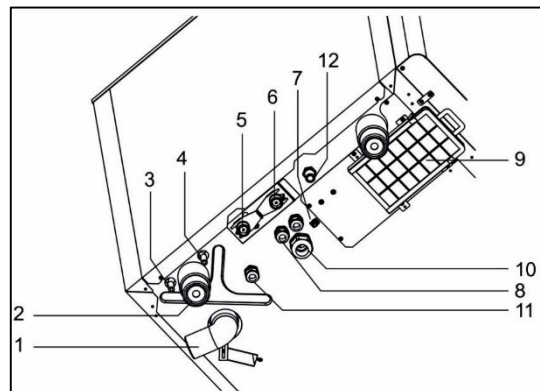



Model: GENIUS^{MT} 6-11 Gas (boilerless)

Standard features

- **MT Technology** - Genuine MultiTouch display with ultrafast response and high resolution. Intuitive and precise **operating** by means of sliding, swiping or scrolling.
- **Quick Set** - Puts all settings in the exact position with your fingertip. Changes or adds temperature and time settings without interrupting the current cooking process on the display.
- **4 Unique Start Screens** manual, climatic^{MT}, favorite, program list
- **9 Menu Groups** - Pasta, Desert/cakes, Bread/rolls, Poultry, Meat, Fish/seafood, Vegetables, Side dishes, Banqueting/Rethermalization
- **9 modes of operation** from 86°F to 572°F with an adjustable humidity between 0% to 100% - Vario-Steaming, Steaming, Forced Steaming, Combi-Steam Cooking, Convection, LT-cooking (cook & hold), Delta-T Cooking, Baking
- **Favorite** - Customized listing for fully automatic programs.
- **Images** - Saves individual product images.
- **Last 20** - Function display allows selection of the 20 most recently used cooking processes including manual and programmed settings for immediate restart.
- **Multi Cooking** - automatically selects programs with the same cooking method and displays up to 15 timers interchangeably and simultaneously on screen.
- **Climate Control** - Patented Climatic^{MT} controls temperature and moisture level. Active humidification and/or de-humidification. Dry heat and humidity in combination with temperature and humidity graphically displayed.
- **Climatic^{MT}** - simultaneous setting of temperature and humidity to the exact degree and percentage, temperature (°C/°F), air humidity, time, core temperature, humidity quantity, pause times
- **Program capacity** - An integrated 9 Menu group display including a library with up to 400 recipes with 20 steps each and 400 product pictures.
- **Quick Mode** - An operating concept especially adapted to the needs of a multi unit operator. It allows using only set recipes and no manual change.
- **Multi Connect** - Easy administration of multiple units with ProConnect^{MT} software and advanced communication interfaces such as LAN or USB.
- **Preconfigured start time** for automatic start at a freely selected time, up to 24h
- **Cook and Hold** - Slow cooking from 86°F to 248°F.
- **Delta-T cooking** - cooking processes regulated in accordance with the core temperature
- **Regeneration** - storable special programs for regeneration of banquets, plates and hotel pans
- **Steptronic[®]** - automatic program sequences using variable combination of cooking steps
- **Core temperature control** for multi-point probe for precise measurement of the core temperature from 32 °F to 210 °F, control of cooking procedures and explain correction in case of false core temperature probe readings.
- **Visual Alarm** - interior lights blinking at the end of cooking program
- **HACCP log book** - automatic internal recording and display of HACCP/LMHV data
- **Half Energy Feature (e/2)** - Reduced electrical load. Ideal in peak times.
- **SPS[®]** - Steam Protection System for prevention of burns using active steam extraction at the end of the cooking process
- **Heat Exchanger** - Heat recovery through Multi-Eco System. Pre-heats incoming water for on-demand steam generation. Highly water and energy efficient. Exceeds drain temperature standards for most municipalities.
- **autoclean^{MT}** - Patented fully-automatic technology. 100% process-controlled for guaranteed hygiene. Reduced consumption of water and rinsing agents - quick clean in 15 minutes. Color-coded indicator of care product shows remaining quantities. No manual cool-down required. No direct employee contact with cleaning agents. Biodegradable cleaning/rinsing agents. Delayed start time possible.
- **5 fan speed levels** - in 5 increments or preconfigured fan timer function or pulsing, fan auto reverse for even browning
- **Manual steam injection** at any time. No pre-heating or stand-by required. Significant energy and water savings.
- **Steam Extraction** - Steam extracted via patented Steam Protection System (SPS[®]) before program ends. Reduces danger of steam burns. Reduces excess humidity in the kitchen environment. Recirculation system reuses steam for maximum energy efficiency.
- **Active Temp** - automatic preheating or cooling of the cooking chamber to set temperature
- **Fan-forced metal fibre burner** - with combustible gas mixture in pre-chamber
- **High-performance triple tube heat exchanger** - for highly efficient energy transfer
- **Cleaning Alert** - adjustable from 5-100 hours
- **Maintenance Alert** - adjustable from 1-12 months
- **Safety door lock** - 2-step door lock, to reduce the risk of burning due to steaming during opening the door
- **Integrated- self-retracting hand shower** with adjustable spray functions and automatic rewind
- **Sensor- controlled steam cooling** - for reducing the steam emission out of the exhaust air pipe
- **KDA service** - test program for quick checks

Eloma North America 101 Corporate Woods Parkway Vernon Hills IL 60061 / USA

Direct: 847-215-6491 Free: 844-ELOMAUS(356-6287) Fax: 336-217-8807

sales@elomausa.com www.elomausa.com



Model: GENIUS^{MT} 6-11 Gas (boilerless)

Description

The unit is a boilerless, self-cleaning, combi oven designed for steaming and convection cooking either separately, sequentially or combined. The combi oven has live-steam system that generates steam directly into the cooking chamber, for faster heating and re-heating without requiring a stand-by mode. An award winning Multi-Eco system simultaneously pre-heats incoming water and cools outgoing condensate to reduce energy and water consumption. The oven fits 6 full size sheet pans or 6 steam table pans.

Construction:

- Constructed to withstand temperature range from 86° to 572°F and humidification from 0% to 100%.
- Hygienic cooking chamber with coved corners, seamless welding. Interior and exterior housing of chrome nickel steel CrNi 18 10, BS 304 S15, AISI 304.
- Tempered door glass (with hinged double panes for easy cleaning) with lock-in-place positions, ventilated door, removable door gaskets & integrated drip tray.
- Quick release safety door lock for single-handed operation.
- Automatic fan break when door opens by contact-free magnetic front size switch.
- Integrated, external hand shower, with automatic return and shut off - for use with door opened or closed.
- Bright interior lighting with halogen lamps integrated in the door, for easy exchange.
- Exhaust and/or seal integrated in drain - fixed connection in accordance with national and international regulations. Sensor controlled, two-stage cool down water condensation (max. discharge temperature 176 °F).
- Split water connections for hard and soft water.
- Hinged control panel - easy service access from the front.
- Rack can be easily removed without tools and has a pan slide stop.
- Manufactured according to quality management system EN ISO 9001.
- IPX 5 Water-tight rating.

Options

- LAN interface
- External core temperature probe
- Connection for energy improvement
- Heat shield

System accessories

- Stacking kit for two units 6-11 + 6-11 without hoods
- ProConnect programming software
- Ocean version
- Vario insert rack for Hotel pans only
- Mobile tray racks, insert racks
- SmokeFit smoker unit (WORKS ONLY FOR UNITS WITHOUT CONDENSATION HOOD)



Model: GENIUS^{MT} 6-11 Gas (boilerless)

Minimum clearance for operation and maintenance work

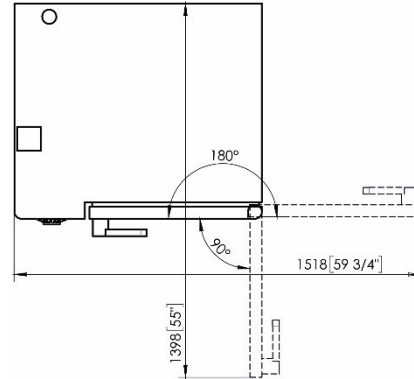
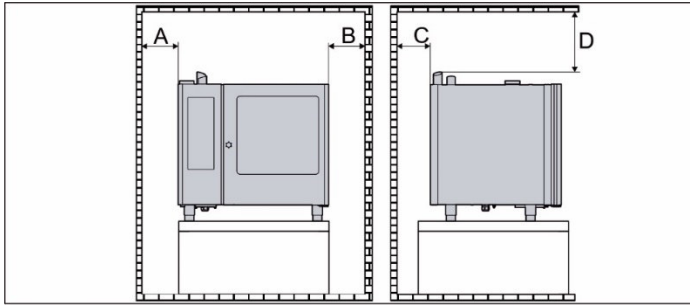

Dimension	Clearance [inch (mm)]	Table-top devices
A	Side with operating panel to the wall	
	Minimum clearance	> 2 (50)
	Recommended free space for maintenance / repair	-
B	Side without operating panel to the wall	
	Minimum clearance	> 2 (50)
C	Rear of the combi steamer to the wall	
	Minimum clearance	> 2 (50)
D	Top edge of the exhaust air pipe to the ceiling	
	Exhaust hood provided by the operating company	> 2 (50)
	Without exhaust hood provided by the operating company	> 39 3/8 (1000)
Min. distance	To Broiler, flat top, open flames, fryers without heatshield	> 10 inch
	with heat shield	> 2 1/2 inch

Weight und Shipping dimensions:

Weight		Shipping dimension		
Max. load per shelf:	33 lbs / 15 kg	Width	Depth	Height
Max. load size:	66 lbs / 30 kg	41 2/3 inch/ 1060 mm	42 1/8 inch/ 1070 mm	41 2/3 inch/ 1060 mm
Net load device:	291 lbs / 132 kg	Freight class	class 150	
Shipping load device:	342 lbs / 155 kg	Cubing	one unit per pallet	
		packing		



Eloma North America 101 Corporate Woods Parkway Vernon Hills IL 60061 / USA
 Direct: 847-215-6491 Free: 844-ELOMAUS(356-6287) Fax: 336-217-8807
sales@elomausa.com www.elomausa.com



Please note:
Based on the water quality in your area, a water filtration system is required. Any filter applied should be sized to handle the flow rate of the device selected, as well as achieve the water quality specified.

Model: GENIUS^{MT} 6-11 Gas (boilerless)

