



PROFESSIONAL  
THINKING

# PRODUCT SHEET EKL 1264

TECNOEKA SRL - VIA MARCO POLO, 11 - 35010 BORGORICCO - PADOVA - ITALY - TEL. +39 049 5791479 +39 049 9300344 - FAX +39 049 5794387 - E-MAIL: INFO@TECNOEKA.COM - WWW.TECNOEKA.COM - WWW.TECNOEKA.RU

## EKL 1264 – PROOFER WITH HUMIDIFICATION 12 TRAYS/GRIDS (600x400 mm)

EKA EVOLUTION LINE

PROOFERS



A modern and efficient proofer that allows you to get the most out of each dough mixture every time, thanks in part to the manual button used to generate humidity and the handy condensate drip tray.

It features a modular design so that it goes with all ovens from the 6-7 and 10-11 pan series, except those from the Touch range.

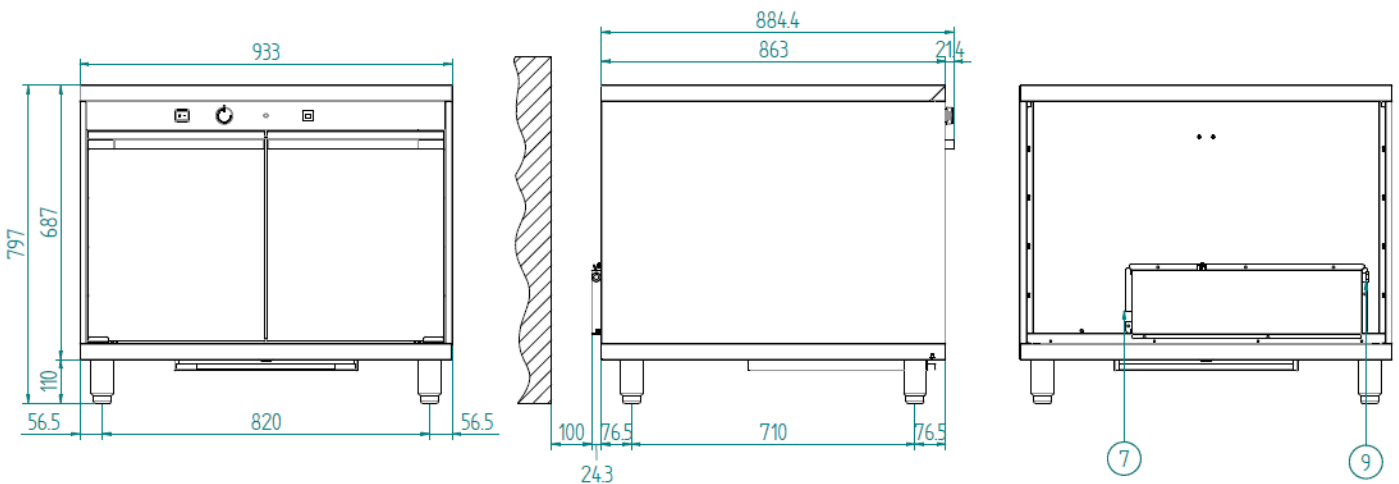

LEGEND

1	USB PORT	11	DON'T CLOG UP VENTILATION OPENINGS
2	SERIAL PORT	12	WATER INLET MAX. 200 kPa
3	PLUG FOR CORE PROBE	13	SOFTENED WATER INLET MAX. 200 kPa
4	WATER OUTLET TUBE	14	BOILER CLEANING INLET
5	WASHING WATER INLET	15	DON'T OPEN CAP WHILE WORKING
6	SOFTENED WATER INLET	16	GAS INLET THREADED JOINT 3/4"
7	WATER INLET	17	POWER SUPPLY TO TOP OVEN
8	STEAM OUTLET	18	PRE-CARVED HOLE FOR BOTTOM OVEN POWER SUPPLY
9	ELECTRIC CABLE FIXER	19	STEAM SUCTION PIPE
10	CAUTION! HOT SURFACE		



DIMENSIONAL FEATURES			FUNCTIONAL FEATURES		
<b>DIMENSIONS</b>	<b>W</b>	<b>D</b>	<b>H</b>	POWER	ELECTRICITY
PROOFER DIMENSIONS (mm)	935	910	800	CAPACITY	N° 12 TRAYS (600x400 mm)
CARDBOARD BOX DIMENSIONS WITH PALLET (mm)	1020	960	875	TYPE OF COOKING	/
PROOFER DIMENSIONS (inches)	36,81	35,82	31,49	HUMIDIFICATION (see legend)	INDIRECT WITH BUTTON
CARDBOARD BOX DIMENSIONS WITH PALLET (inches)	40,15	37,79	34,44	PROOFING CHAMBER	AISI 430 STAINLESS STEEL
PROOFER WEIGHT (kg)	57,71			WATER OUTLET	/
PACKED PROOFER WEIGHT (kg)	75,51			STEAM OUTLET	/
PROOFER WEIGHT (lbs)	127,22			TEMPERATURE	30 ÷ 60°C
PACKED PROOFER WEIGHT (lbs)	166,47			TEMPERATURE CONTROL	THERMOSTAT
DISTANCE BETWEEN RACK RAILS (mm)	75			CONTROL PANEL	ELECTROMECHANICAL – TOP SIDE
<b>ELECTRICAL FEATURES</b>			N° OF PROGRAMS		
POWER SUPPLY (kW)	2,4			PROGRAMMABLE COOKING STEPS	/
FREQUENCY (Hz)	50/60			PRESET TEMPERATURE	/
VOLTAGE (Volt)	AC 220/230			PRE-HEATING FUNCTION	/
N° OF MOTORS	/			DOOR	DOUBLE LEAF
RPM	/			<b>EQUIPMENT</b>	
N° OF RESISTORS	2 X 1,2 kW			LATERAL SUPPORTS	1RIGHT + 1LEFT
LIMIT CONTROL	/			CABLE	SINGLE-PHASE [3G 1,5] - L=1600 mm
PROTECTION AGAINST WATER	/			REMOVABLE DRIP BOX	
LIGHTING	/				
<b>PLUS</b>			<b>MODULARITY</b>		
NEW DOOR				OVENS	EKF 664 AND EKF 1064 SERIES

LEGEND

**HUMIDIFICATION**



Water is filled in a drip box behind the air conveyor grid.  
Sort of activation: with button or with knob.  
Ideal for recipes that need humidity (for example roast meat).